

# LIBERATING STRUCTURES



















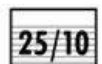















## IMPULSIONANDO SUA PRÁTICA DE FACILITAÇÃO



JONATAN AGUIAR – AGILISTA NA UNICRED DO BRASIL



# O que são estruturas libertadoras?

Impromptu networking 	TRIZ 	What <sup>3</sup> debrief 	Conversation café 	Appreciative interviews 	1-2-4 rapid conversation 	5-whys 
Ecocycle planning 	Shift & share 	25 > 10 crowdsourcing 	Min - specs 	Wise crowds 	Wicked Q's 	Purpose to practice 
Agree/certainty matrix 	What I need from you 	User experience fishbowl 	Heard, seen, respected 	Smart network webbing 	Design with storyboards 	Open space technology 
Integrated autonomy 	Generative relationships 	Critical uncertainties 	Graphic recording 	Panarchy 	Troika consulting 	Helping heuristics 
Celebrity interview 	Stories To Patterns 	15% solutions 	LS 	Improv prototyping 	Discovery and action dialogue 	Simple ethnography 

- São uma seleção de 33 estruturas para **facilitação**,
- **Curadoria de Henri Lipmanowicz e Keith McCandless.**
- **Autores do livro “The Surprising Power of Liberating Structures”**
- **Quando você se sente incluído e engajado, você trabalha melhor?**
- **Você acha que times em que as pessoas trabalham bem juntas produzem resultados muito melhores?**

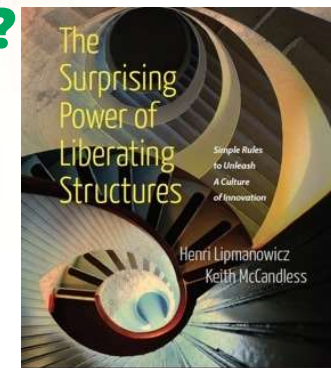

# Trabalhando com Estruturas Libertadoras

- Uma primeira experiência é suficiente para começar
- VOCÊ vai decidir como alcançar o domínio
- EL são simples, poderosas e sutis
- EL são fáceis de copiar e disseminar
- Trabalhar em parceria enriquece a aprendizagem

Henri Lipmanowicz & Keith  
McCandless

Todos pensam em mudar o mundo, mas  
ninguém pensa em mudar a si mesmo.  
*Tolstoy*



# Princípios

1. **Inclua e Libere todos**
2. **Pratique profundo respeito pelas pessoas e soluções locais**
3. **Construa confiança ao longo do caminho**
4. **Aprenda errando (caindo para frente)**
5. **Pratique a auto-descoberta a partir do grupo**
6. **Amplifique Liberdade E Responsabilidade**
7. **Dê ênfase às possibilidades: Crer pra ver**
8. **Convide a destruição criativa para possibilitar a inovação**
9. **Engage em uma curiosidade seriamente-divertida**
10. **Jamais comece sem um propósito claro**

# ATRIBUTOS DAS ESTRUTURAS LIBERTADORAS

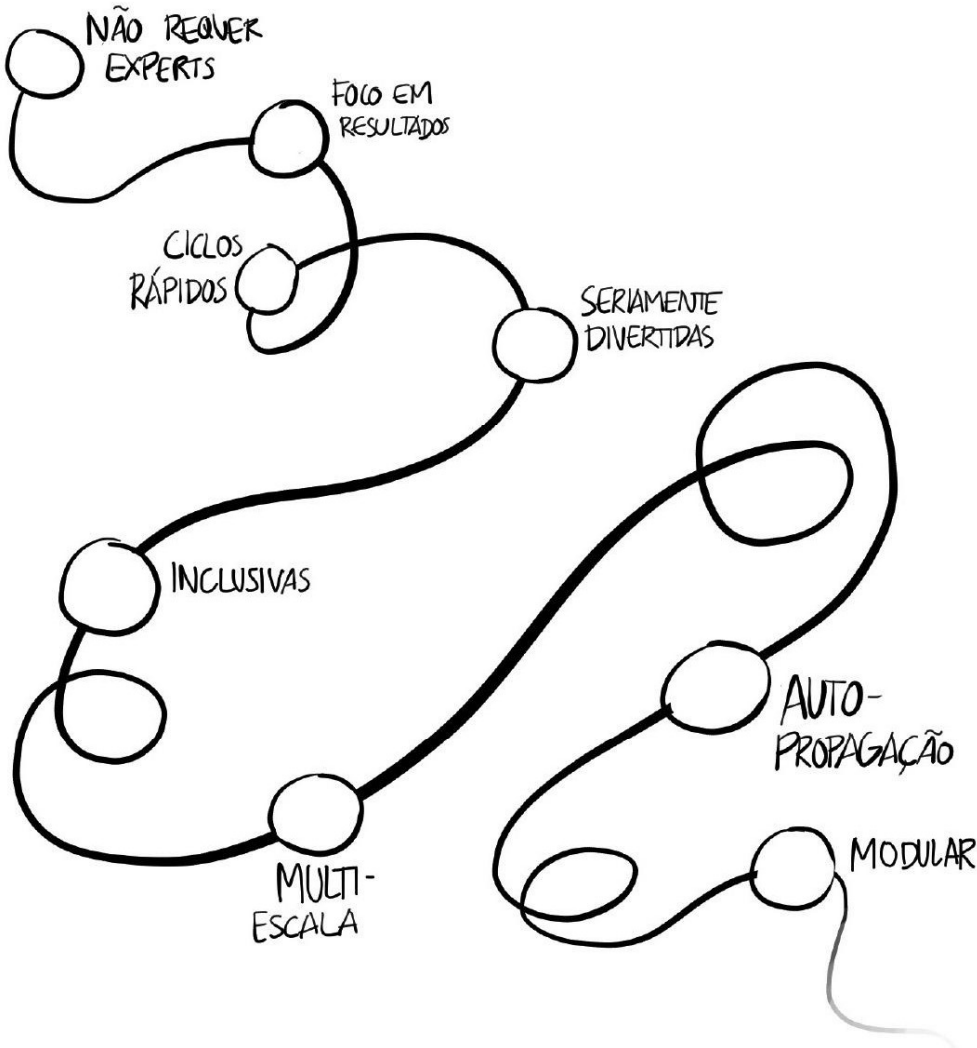

# ANATOMIA DE UMA EL

TÍTULO DIVERTIDO	[ IMPROMPTU NETWORKING
PROPÓSITO CLARO	
ICONE	[ 
ETAPAS & TEMPOS	[ Sequência de passos e tempo

1. Encontra alguém
2. Gongo \*ding\*
3. Troca de parceiros
4. ....
5. ...

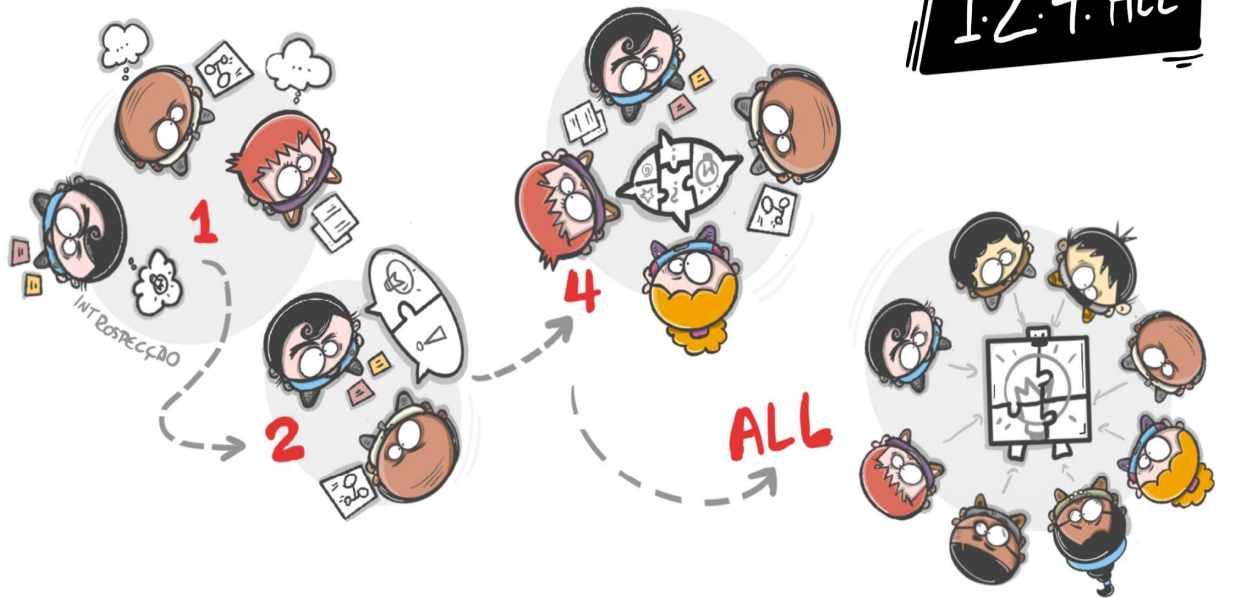

## 1.2.4.ALL

PROPÓSITO: ENGAJE TODOS SIMULTANEAMENTE NA GERAÇÃO DE PERGUNTAS, IDEIAS E SUGESTÕES.

ICONE:



ETAPAS:

- REFLEXÃO INDIVIDUAL SILENCIOSA PELOS INDIVÍDUOS EM UM DESAFIO COMPARTILHADO.
- GERAR IDEIAS EM PARES, CONSTRUINDO EM CIMA DAS IDEIAS RESULTANTES DA AUTO-REFLEXÃO.
- COMPARTILHAR E DESENVOLVER AS IDEIAS DO SEU PAR EM UM QUARTETO (NOTAR SEMELHANÇAS E DIFERENÇAS)

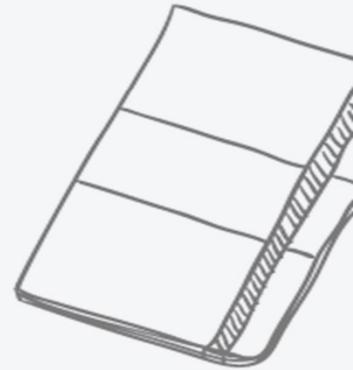



## Micro-estruturas

Convite

Sequência  
de Passos  
e Tempo

Espaço e  
Materiais

O CONVITE É A PERGUNTA OU TÓPICO QUE VOCÊ DESEJA QUE AS PESSOAS explorem  
COM A ESTRUTURA LIBERTADORA QUE VOCÊ TEM EM MENTE  
POR EXEMPLO: "QUAL SERIA O MELHOR RESULTADO QUE PODEMOS ALCANÇAR HOJE?"

Configuração  
do Grupo

Como a  
Participação é  
Distribuída



## Micro-estruturas

Convite

COMO O ESPAÇO É ORGANIZADO E QUAIS MATERIAIS SÃO USADOS, REFERE-SE A TODAS AS OPÇÕES QUE VOCÊ POSSUI ELEMENTOS TANGÍVEIS E INTANGÍVEIS, COMO MESAS, CADEIRAS, PROJETOR, PAPEL, FLIPCHARTS OU COMO USAR O ESPAÇO, POR EXEMPLO: FRENTE A FRENTE OU SENTADO EM UM CÍRCULO.

Configuração  
do Grupo

Como a  
Participação é  
Distribuída





## Micro-estruturas

Convite

Sequência  
de Passos

Espaço e  
Materiais

COMO A PARTICIPAÇÃO É DISTRIBUÍDA ESCLARECE QUANTO TEMPO CADA PARTICIPANTE TERÁ PARA CONTRIBUIR (POR EXEMPLO: "DIVIDA 10 MINUTOS ENTRE VOCÊS QUATRO").

Configuração  
do Grupo

Como a  
Participação é  
Distribuída



## Micro-estruturas

Convite

Sequência  
de Passos  
e Tempo

Espaço e  
Materiais

COMO OS GRUPOS SÃO CONFIGURADOS REFERE-SE À COMPOSIÇÃO DE UM GRUPO  
(POR EXEMPLO: PRIMEIROS PARES E DEPOIS GRUPOS DE QUATRO)

Configuração  
do Grupo

Como a  
Participação é  
Distribuída



## Micro-estruturas

Convite

Sequência  
de Passos

Espaço e  
Materiais

O ELEMENTO FINAL DO PROJETO É SOBRE A SEQUÊNCIA DE ETAPAS E O TEMPO ALOCADO PARA CADA ETAPA (POR EXEMPLO: 1 MINUTO SOZINHO, 2 MINUTOS EM PARES, 4 MINUTOS EM GRUPOS DE QUATRO).

Configuração  
do Grupo

Como a  
Participação é  
Distribuída

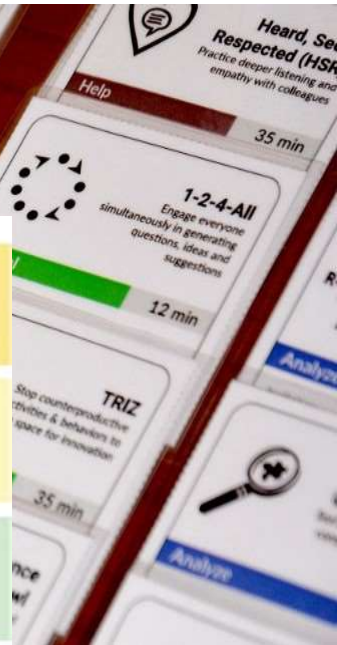
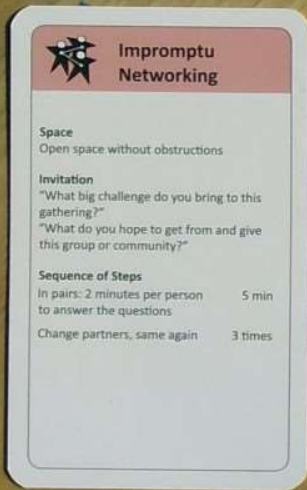

**Planejar**

**Dar ou Pedir Ajuda**

**Analisar, Diagnosticar ou Refletir**

**Revelar, Gerar, Melhorar Ideias ou Soluções**

**Compartilhar ou Disseminar Ideias**

**Desenvolver Estratégias**







QUAL É A JUSTIFICATIVA  
FUNDAMENTAL E A  
NECESSIDADE MAIS  
PROFUNDA DE NOSSO  
TRABALHO?



O QUE ESTÁ ACONTECENDO  
AO NOSSO REDOR QUE  
EXIGE MUDANÇA CRIATIVA?

A person is standing on a tall, dark metal ladder that extends from the bottom left towards the top left of the frame. The person is seen from the back, wearing a light-colored t-shirt and dark shorts. They have their right arm raised and are looking towards the sky. The background is a vast, blue sky filled with soft, white clouds. The overall mood is one of aspiration and contemplation.

QUAIS SÃO OS PARADOXOS  
QUE DEVEMOS ENFRENTAR  
PARA PROGREDIR?



A person is standing on a tall, dark metal ladder that extends from the bottom left towards the top left of the frame. The person is seen from the back, wearing a light-colored t-shirt and dark shorts. They have their right arm raised and are looking towards the sky. The background is a vast, blue sky filled with soft, white clouds. The overall mood is one of aspiration and contemplation.

ONDE ESTAMOS  
COMEÇANDO,  
HONESTAMENTE?

DADO O NOSSO  
PROPÓSITO, O QUE  
PARECE POSSÍVEL  
AGORA?





COMO ESTAMOS AGINDO  
EM DIREÇÃO AO FUTURO,  
AVALIANDO O QUE É  
POSSÍVEL À MEDIDA QUE  
AVANÇAMOS?



"EMBORA OS FACILITADORES POSSAM ATUAR COMO "TRAINING WHEELS", SEU OBJETIVO DEVERIA SER AJUDAR OS ALUNOS A FAZÊ-LO SEM ELES."

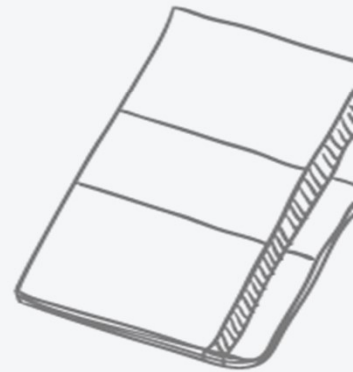

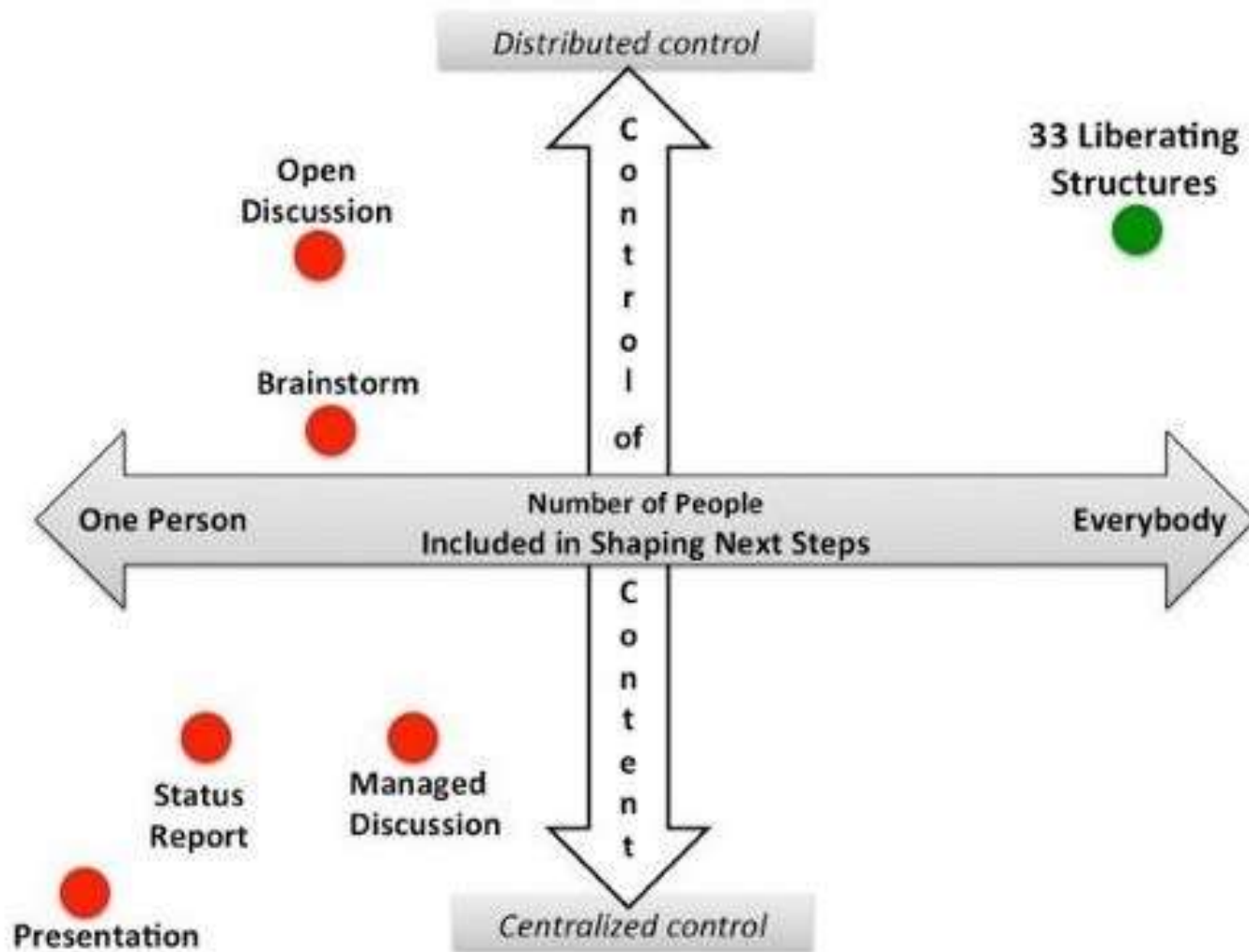



"COMO LIBERATING STRUCTURES AND LEARNING 3.0  
SE COMPLEMENTAM?"

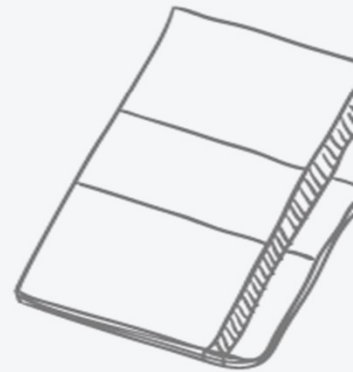

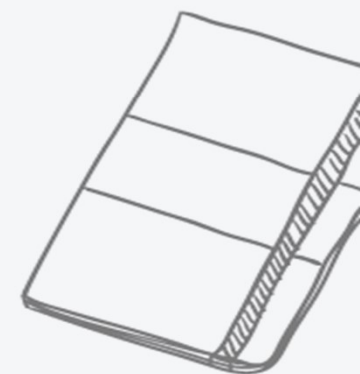

1.0



Experts define questions and answers

O ESPECIALISTA DEFINE AS PERGUNTAS E RESPOSTAS

2.0



Learners define questions but experts define answers

O ALUNO DEFINE PERGUNTAS, O ESPECIALISTA FORNECE A RESPOSTA

3.0



Learners define both questions and answers

O ALUNO DEFINE PERGUNTAS E RESPOSTAS



## "COMPARTILHAR É O NOVO ENSINAMENTO"

CABE AO FACILITADOR CRIAR UM AMBIENTE EM QUE OS PARTICIPANTES SEJAM CONVIDADOS A COMPARTILHAR EXPERIÊNCIAS E CRIAR UM ESPAÇO DE APRENDIZADO.



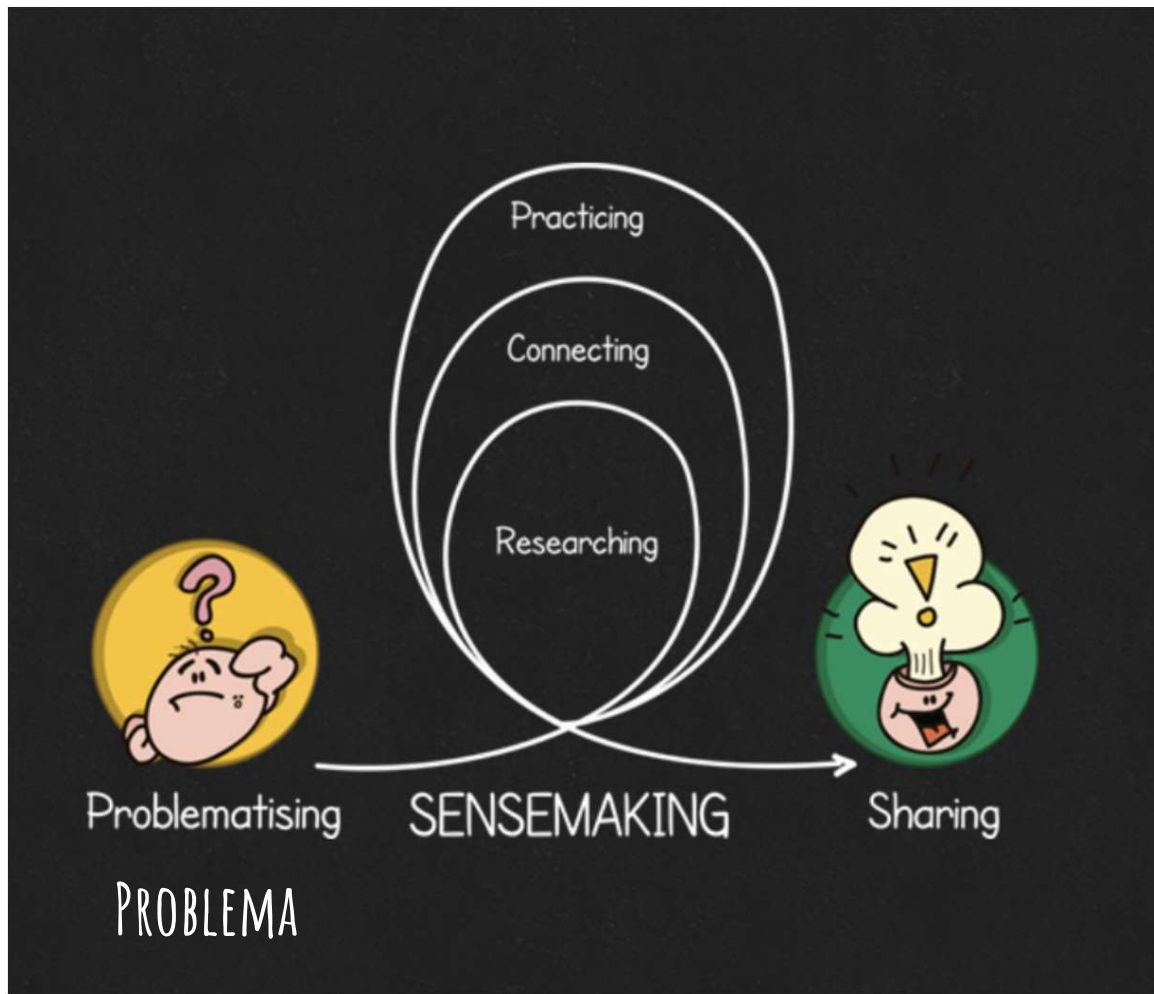

<p>Impromptu networking</p>	<p>TRIZ</p>	<p>What<sup>3</sup> debrief</p>	<p>Conversation café</p>	<p>Appreciative interviews</p>
<p>Ecocycle planning</p>	<p>Shift &amp; share</p>	<p>25 &gt; 10 cloudsourcing</p>	<p>Min - specs</p>	<p>Wise crowds</p>
<p>Agree/certainty matrix</p>	<p>What I need from you</p>	<p>User experience fishbowl</p>	<p>Heard, seen, respected</p>	<p>Smart network webbing</p>
<p>Integrated autonomy</p>	<p>Generative relationships</p>	<p>Critical uncertainties</p>	<p>Graphic recording</p>	<p>Panarchy</p>
<p>Celebrity interview</p>	<p>Stories To Patterns</p>	<p>15% solutions</p>	<p>LS</p>	<p>Improv prototyping</p>



# PROBLEMA ?

ACEITE UM DESAFIO DO MUNDO REAL E SELECIONE MATERIAIS E RESULTADOS QUE AJUDEM A ESCLARECER O PROBLEMA



## WICKED QUESTIONS

QUE ESTRATÉGIAS OPOSTAS, PORÉM COMPLEMENTARES, PRECISAMOS SEGUIR SIMULTANEAMENTE PARA TER SUCESSO?

EXEMPLO: COMO PODEMOS NOS CONCENTRAR EM NOSSOS CLIENTES QUANDO SOMOS FORÇADOS A GASTAR MAIS E MAIS TEMPO NA BUROCRACIA DA MATRIZ?

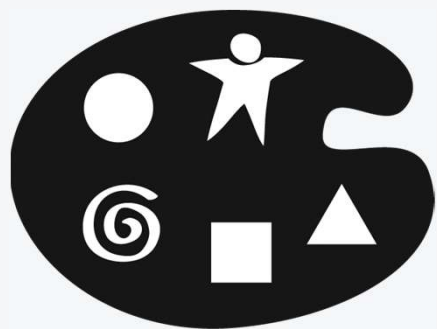

## DRAWING TOGETHER

REVELE IDÉIAS ATRAVÉS DE EXPRESSÕES NÃO-VERBAIS. ÀS VEZES, VOCÊ FICA PARADO AO DESCREVER O DESAFIO QUE ESTÁ ENFRENTANDO SE CONSEGUIR USAR APENAS PALAVRAS. AO VISUALIZAR O PROBLEMA, VOCÊ PODE COMPARTILHAR IDÉIAS QUE DE OUTRA FORMA NÃO APARECERIAM..

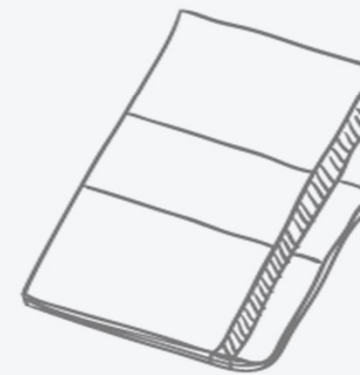

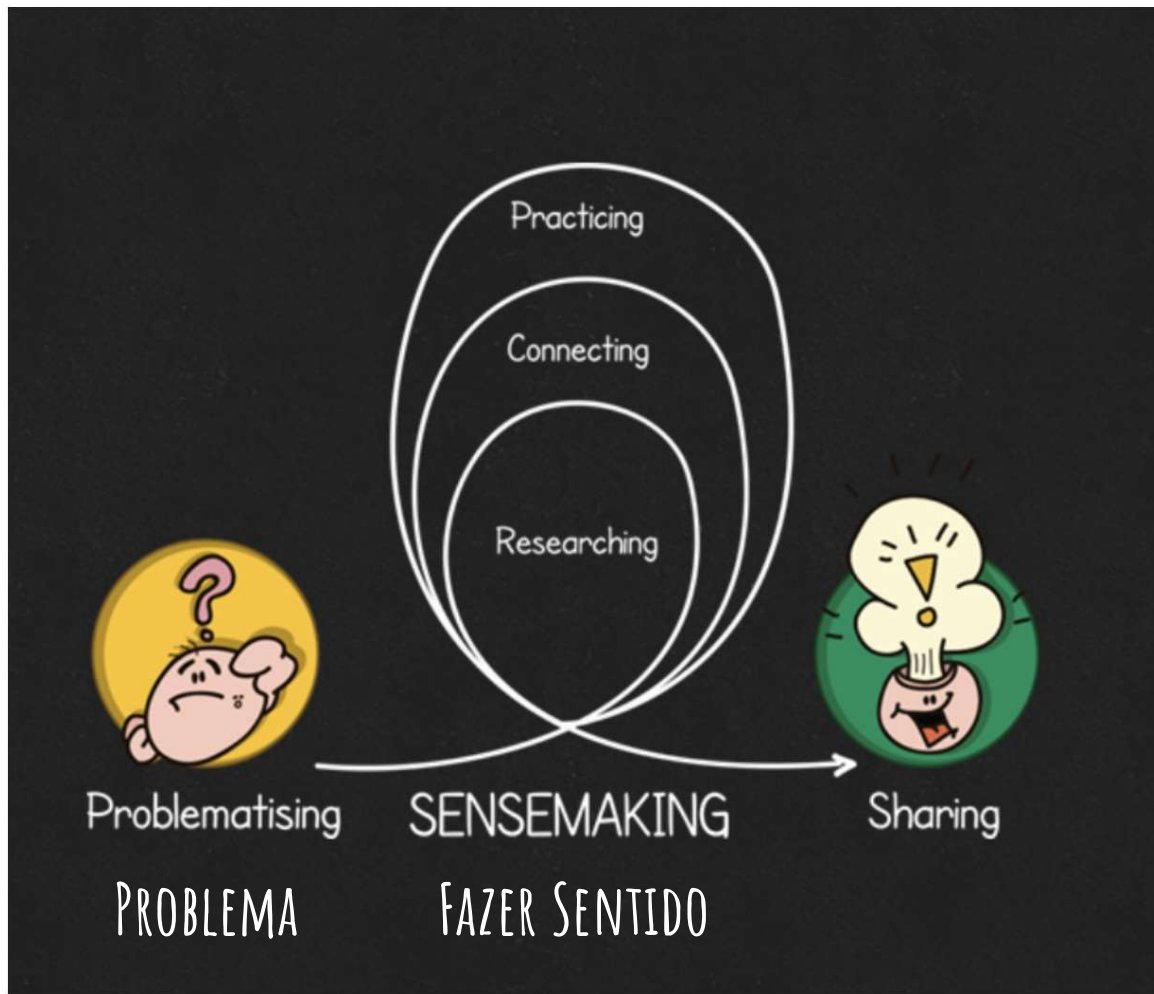

Impromptu networking 	TRIZ 	What <sup>3</sup> debrief 	Conversation café 	Appreciative interviews 
Ecocycle planning 	Shift & share 	25 > 10 crowdsourcing 	Min - specs 	Wise crowds 
Agree/certainty matrix 	What I need from you 	User experience fishbowl 	Heard, seen, respected 	Smart network webbing 
Integrated autonomy 	Generative relationships 	Critical uncertainties 	Graphic recording 	Panarchy 
Celebrity interview 	Stories To Patterns 	15% solutions 	LS 	Improv prototyping 



# FAZER SENTIDO ?

DÊ SENTIDO AO MATERIAL COLETADO QUE COLIDIRÁ COM O SEU MUNDO REAL FAZENDO PESQUISAS, FAZENDO CONEXÕES COM OUTRAS PESSOAS E SIMPLEMENTE PRATICANDO



## CRITICAL UNCERTAINTIES

DESENVOLVA ESTRATÉGIAS PARA RESPONDER RAPIDAMENTE A DESAFIOS FUTUROS COM INCERTEZAS CRÍTICAS. QUAIS SÃO OS FATORES INCERTOS ALÉM DO SEU CONTROLE AO INICIAR OU PARAR UMA ATIVIDADE?



## DISCOVERY & ACTION DIALOGUE (DAD)

DESCUBRA, INVENTE E LIBERE SOLUÇÕES LOCAIS PARA PROBLEMAS CRÔNICOS. COMPREENDA O DESAFIO E DETERMINE OS PRÓXIMOS PASSOS, FAZENDO PERGUNTAS COMO: "COMO VOCÊ SABE QUANDO O PROBLEMA ESTÁ PRESENTE?" E "COMO VOCÊ CONTRIBUI EFETIVAMENTE PARA RESOLVER O PROBLEMA?" ..

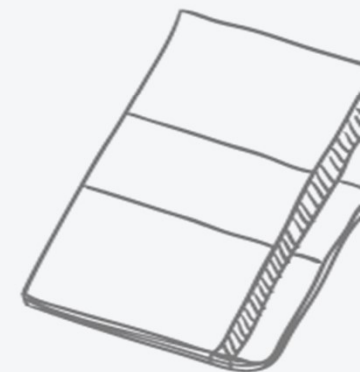

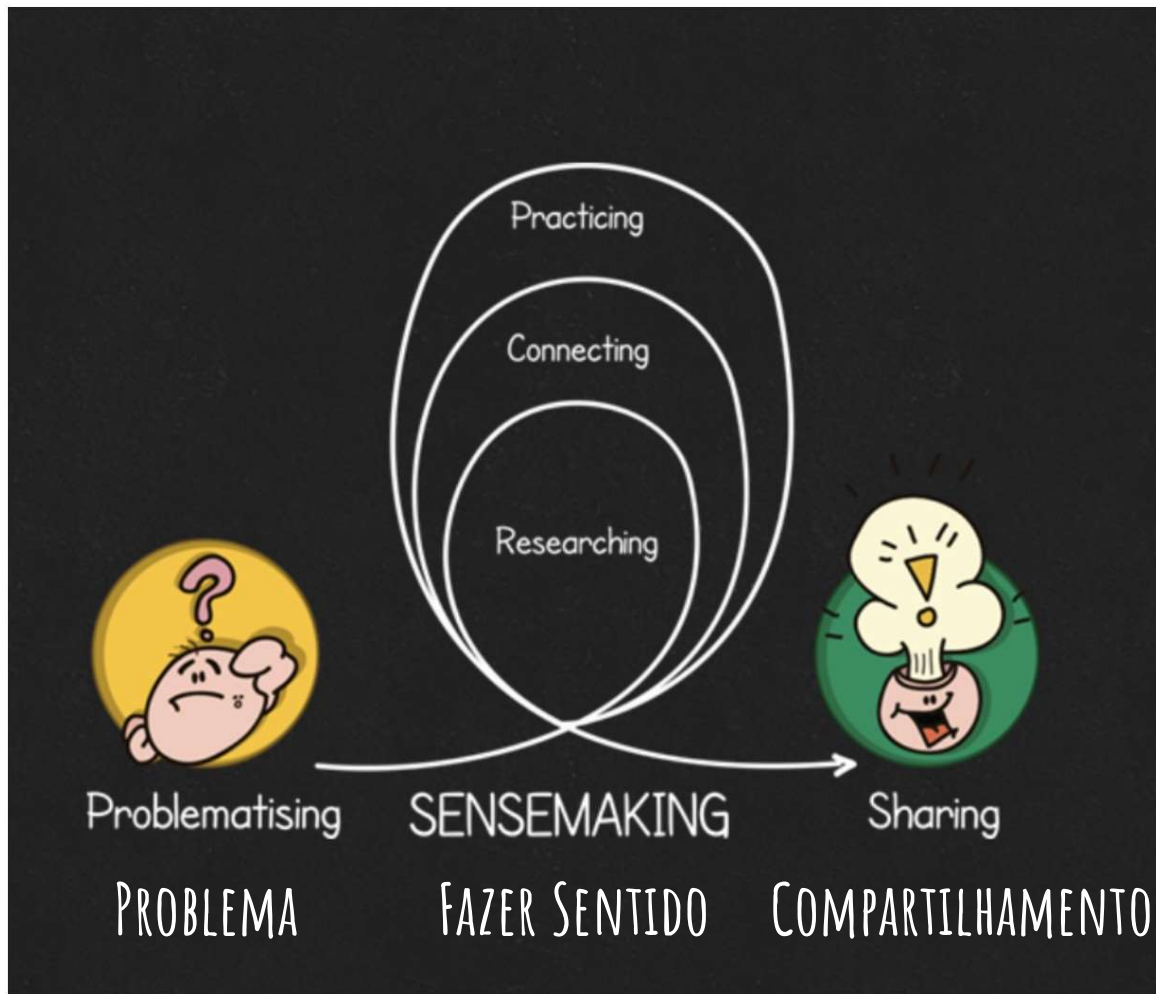

<p>Impromptu networking</p>	<p>TRIZ</p>	<p>What<sup>3</sup> debrief</p>	<p>Conversation café</p>	<p>Appreciative interviews</p>
<p>Ecocycle planning</p>	<p>Shift &amp; share</p>	<p>25 &gt; 10 cloudsourcing</p>	<p>Min - specs</p>	<p>Wise crowds</p>
<p>Agree/certainty matrix</p>	<p>What I need from you</p>	<p>User experience fishbowl</p>	<p>Heard, seen, respected</p>	<p>Smart network webbing</p>
<p>Integrated autonomy</p>	<p>Generative relationships</p>	<p>Critical uncertainties</p>	<p>Graphic recording</p>	<p>Panarchy</p>
<p>Celebrity interview</p>	<p>Stories To Patterns</p>	<p>15% solutions</p>	<p>LS</p>	<p>Improv prototyping</p>



# COMPARTILHAMENTO ?

COMPARTILHE O CONHECIMENTO E AS IDÉIAS CONSTRUÍDAS



## SHIFT & SHARE

COMPARTILHE IDÉIAS INOVADORAS E SOLUÇÕES CRIATIVAS ENTRE GRUPOS. OS PARTICIPANTES EXIBEM SUAS IDÉIAS OU PRODUTOS E OBTÊM FEEDBACK SIGNIFICATIVO EM CICLOS CURTOS.



## CONVERSATION CAFÉ

ENVOLVA TODOS NA COMPREENSÃO DE DESAFIOS PROFUNDOS ENQUANTO DESCOBRE COMO DIFERENTES PERSPECTIVAS LEVAM A UM ENTENDIMENTO MAIS RICO EM VEZ DE DIVISÃO. ELE ENCORAJA AS PESSOAS A OUVIR E ENTENDER AS PERSPECTIVAS UMAS DAS OUTRAS SOBRE UM TÓPICO OU DESAFIO PROFUNDO E COMPARTILHADO, EM VEZ DE TENTAR CONVENCER OU CONVENCER OS OUTROS A VÊ-LO DO SEU JEITO...

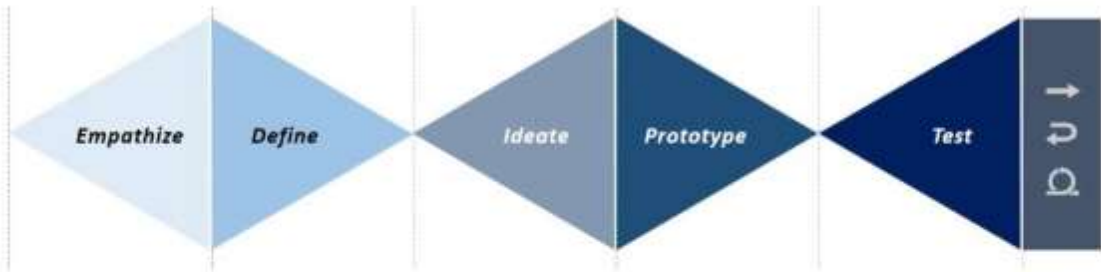

# Design Thinking + Liberating Structures



DOMINAÇÃO: A MINORIA VOCAL DOMINA O ESPAÇO,

NOSSO MEDO DE ESTAR ERRADO E PARECER ESTÚPIDO NOS FAZ CALAR A BOCA.

AS IDÉIAS EVAPORAM: NOSSAS IDÉIAS NASCENTES SE DISSIPAM RAPIDAMENTE ENQUANTO ESPERAMOS A NOSSA VEZ DE FALAR.

PREGUIÇA SOCIAL: TORNAMO-NOS MENTALMENTE PREGUIÇOSOS EM GRUPOS - DEIXE OS OUTROS PENSAREM!.

<http://bit.ly/2OqwcNn>

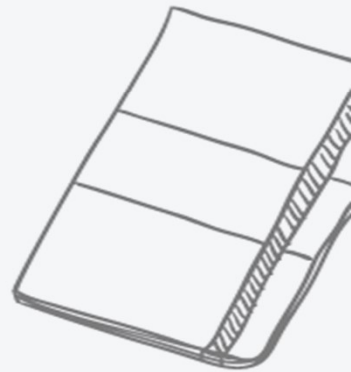



## DESIGN SPRINT & LIBERATING STRUCTURES: A HISTÓRIA DE UM MASH-UP.



<http://bit.ly/2Do4zyl>  
<http://bit.ly/2sfi40P>

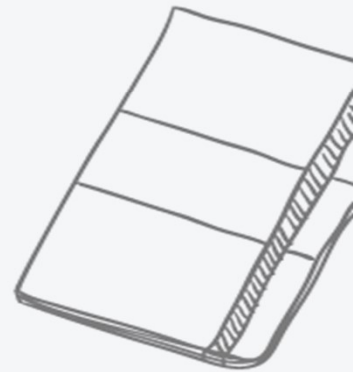





## USING LIBERATING STRUCTURES WITH CHILDREN

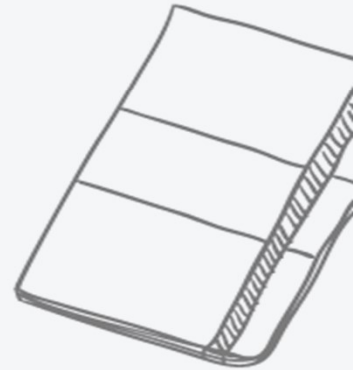

<http://bit.ly/2rztWSE>





Impromptu  
Networking



So what IS  
Liberating  
Structures?

Educators  
Experience  
Fishbowl



15%  
Solution:  
What is  
your next  
step?



Join us for  
more...



Matches: Share



## Impromptu Networking

20 min

Rapidly share challenges and expectations, build new connections

holisticon

Matches: Analyze



## What?, So What?, Now What? W<sup>3</sup>

45 min

Together, look back on progress to date and decide what adjustments are needed

holisticon

Matches: Share



## Celebrity Interview

35 – 60 min

Reconnect the experience of leaders and experts with people closest to the challenge at hand

holisticon

Matches: Reveal



## 15% Solutions

20 min

Discover and focus on what each person has the freedom and resources to do now

holisticon



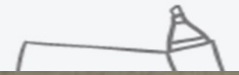

Matches: Share



### Impromptu Networking

20 min

Rapidly share challenges and expectations, build new connections

**Oholisticon**

Matches: Analyze



### Ecocycle Planning

95 min

Analyze the full portfolio of activities and relationships to identify obstacles and opportunities for progress

**Oholisticon**

Matches: Strategize

Matches: Reveal



### 15% Solutions

20 min

Discover and focus on what each person has the freedom and resources to do now

**Oholisticon**

Matches: Help



### Troika Consulting

30 min

Get practical and imaginative help from colleagues immediately

**Oholisticon**

Matches: Reveal





ENTÃO ...



## COMECE COM UM OBJETIVO

É PAPEL DO FACILITADOR DEFINIR A META OU O OBJETIVO DA SESSÃO POIS PERMITE QUE OS PARTICIPANTES TENHAM UM PONTO DE PARTIDA PARA INICIAR O PROCESSO.



## PROPORCIONE LIBERDADE EM LIMITES CLAROS

DEFINIR A ESTRUTURA, INCLUINDO ADICIONAR REGRAS CLARAS SOBRE COMO OS PARTICIPANTES DEVEM SE COMPORTAR, OFERECE A CAPACIDADE DE ORIENTAR O CAMINHO QUE A SESSÃO PERCORRE E PRINCIPALMENTE FORNECER UMA ESTRUTURA QUE TODOS JOGUEM BEM JUNTOS.

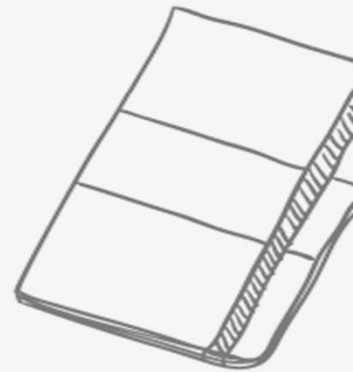

# E ... NÃO ACABOU



## SE SENTIREM SEGURAS

SE TODAS AS VOZES SÃO IGUALMENTE IMPORTANTES E TODAS AS IDEIAS SÃO VALORIZADAS, MELHORAMOS AS CHANCES DE ENCONTRAR AS MELHORES SOLUÇÕES.

## A VOZ É VALIOSA

RECONHECER QUE TODOS PODEM E DEVEM COMPARTILHAR DA ESFERA DE ESPECIALIZAÇÃO, E NEM UMA ÚNICA PESSOA CONHECE TODAS AS SOLUÇÕES PARA UM PROBLEMA. ASSIM COMO AS PESSOAS DIZEM "IT TAKES A VILLAGE TO RAISE A CHILD" ( É PRECISO UMA VILA PARA CRIAR UM FILHO ), TALVEZ TAMBÉM SEJA VERDADE DIZER QUE 'É PRECISO UMA VILA PARA RESOLVER UM PROBLEMA COMPLEXO'.

**15%**

**15% Solutions**

**Para investir mais atenção e energia neste princípio, onde você tem liberdade e autonomia para agir?**

**O que você pode fazer imediatamente sem mais recursos, autoridade ou conhecimento?**

**Quais são seus 15%?**







# MEETUP NMAF NEGÓCIOS, METODOLOGIAS ÁGEIS E FACILITAÇÃO



[HTTPS://WWW.MEETUP.COM/PT-BR/NEGOCIOS-METODOLOGIA-AGIL-FACILITACAO-BRASIL/](https://www.meetup.com/pt-br/negocios-metodologia-agil-facilitacao-brasil/)

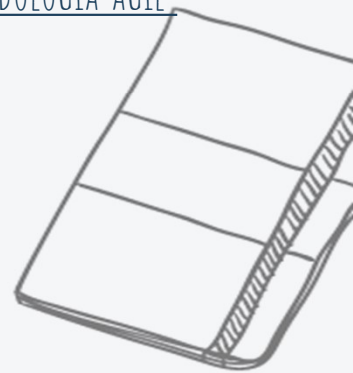

# Materiais

[www.liberatingstructures.com](http://www.liberatingstructures.com)

[www.estruturaslibertadoras.com.br](http://www.estruturaslibertadoras.com.br)



**Liberating Structures**  
by Holisticon AG

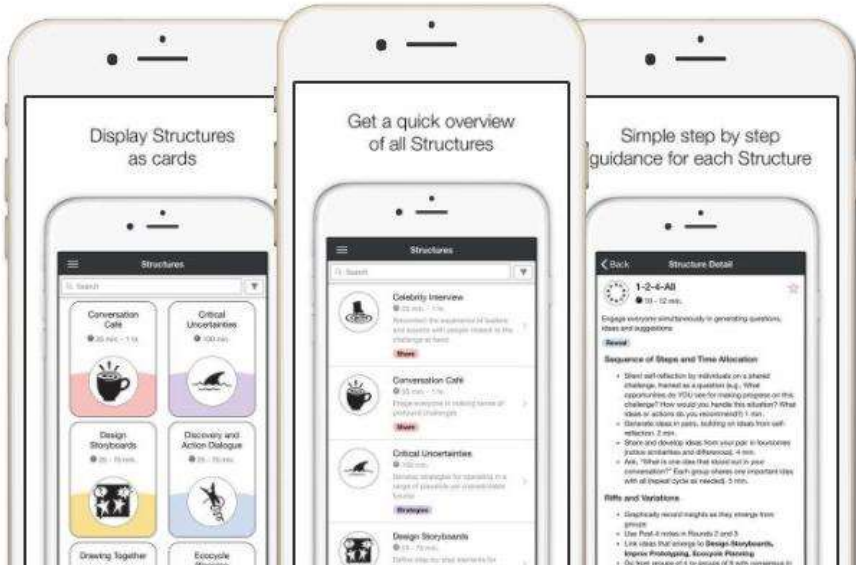

**Wicked Questions**  
25 min.

Articule os desafios paradoxais que um grupo deve enfrentar para ter sucesso

[www.liberatingstructures.com.br](http://www.liberatingstructures.com.br)

**Impromptu Networking**  
20 min.

Compartilhe rapidamente os desafios e as expectativas, crie novas conexões

[www.liberatingstructures.com.br](http://www.liberatingstructures.com.br)

**Panarchy**  
120 min.

Entenda como sistemas interconectados interagem, evoluem, disseminam inovação e transformam

[www.liberatingstructures.com.br](http://www.liberatingstructures.com.br)

**Disponíveis através da Licença Creative Commons  
Não-Comercial, sempre Citando a Fonte**

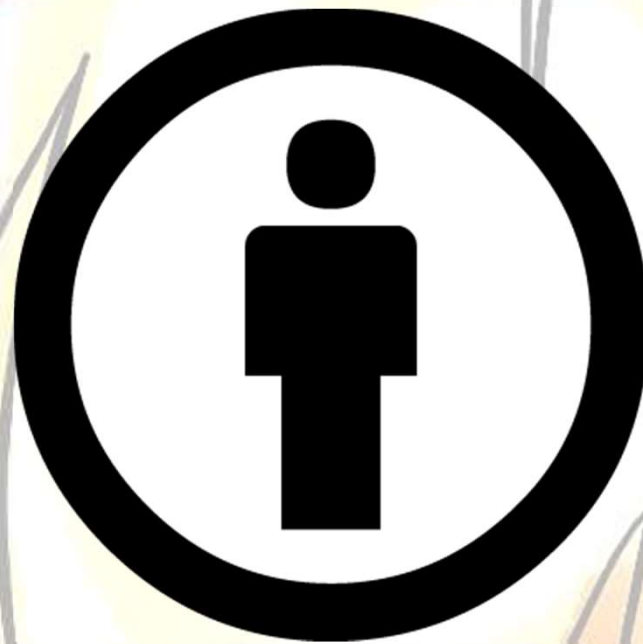

**Você pode usar, compartilhar, mas não vender.**

# THANKS



[www.LiberatingStructures.com.br](http://www.LiberatingStructures.com.br)



[@brinklley](https://twitter.com/brinklley)



<https://www.linkedin.com/in/jonatan-aguiar/>



<https://medium.com/EstruturasLibertadoras>



[Jonatan.aguiar@unicred.com.br](mailto:Jonatan.aguiar@unicred.com.br)